

# LHC Machine Timing Distribution for the Experiments

Taylor, B.G.

CERN, 1211 Geneva 23, Switzerland  
Bruce.Taylor@cern.ch

for the RD12 Collaboration

## Abstract

At the LHC the 40.079 MHz bunch crossing clock and 11.246 kHz machine orbit signal must be distributed from the Preveessin Control Room (PCR) to the TTC systems of the 4 LHC experiments, to the test beam facilities in the West and North areas and to beam instrumentation around the ring.

To achieve this, a single high-power laser transmitter with optical fanout to all the destinations has been installed at the PCR. A standard TTC machine interface (TTCmi) has been developed which receives the signals and can deliver very low jitter timing signals to LHC experiment TTC distribution systems with multiple trigger partitions.

## I. INTRODUCTION

The timing, trigger and control (TTC) distribution systems [1] to be installed at the LHC experiments must be synchronized with the bunch crossings in the machine and the orbit of the circulating beams. In collaboration with CERN SL Division HRF and CO Groups, RD12 [2] has implemented a system which allows the timing signals to be broadcast with the required precision from the Preveessin Control Room (PCR) to the experimental areas over optical fibres.

The system has first been used for broadcasting the timing for the LHC-structured extracted beams which were provided by the SPS for test purposes in May 2000. For this special run, the signals were transmitted to the X5 and X7 test beam areas in the West Hall and H2, H4 and H8 in the North Hall. Satisfactory results were achieved by the ATLAS, CMS and LHCb teams running in these areas [3].

## II. ARCHITECTURE

The overall architecture of the timing distribution system is indicated in the simplified block diagram Fig. 1. The 40.079 MHz bunch clock, 11.246 kHz (pseudo-) LHC orbit signal and 43.375 kHz SPS orbit signal generated by the synthesisers in the BA3 Faraday Cage are transmitted to the PCR by low-loss coaxial cable links with galvanic isolation.

At the PCR, a PLL with low-noise VCXO is used to reduce the jitter of the received bunch clock to about 7 ps rms and the clock and selected orbit signal are biphase

mark encoded. The encoded signal modulates a high-power 1310 nm laser diode, the output of which is fanned out by a 1x32 passive optical tree coupler and broadcast over a singlemode optical fibre distribution network.

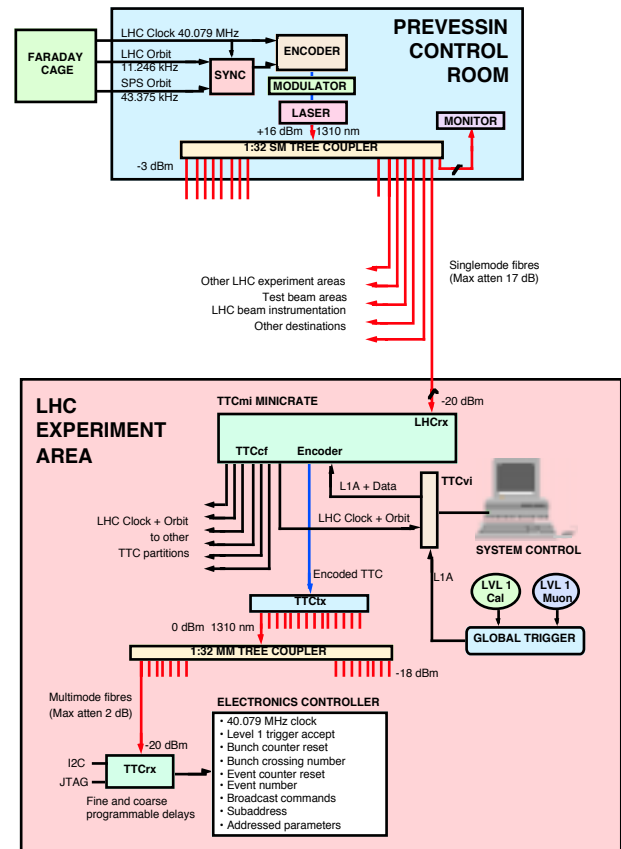

Figure 1: Overall block diagram of TTC distribution

At the experimental areas, the optical signals are received by a TTC machine interface (TTCmi) which monitors and decodes them, cleans up the bunch clock and adjusts the global phase of the orbit signal. The TTCmi then distributes the timing signals to up to 40 local TTC distribution systems for the different trigger partitions of the experiment.

## III. DISTRIBUTION FIBRE

Preliminary tests were carried out over singlemode and multimode fibre loops which were installed between the PCR and Building 4. Although the line of sight distance

is only about 2.5 km, the optical fibres follow the SPS ring via BA2 and BA1 and are routed through patchboards in several surface buildings and the basement of the CERN telephone exchange, resulting in a one-way path length of 6.5 km. The round-trip B4-PCR-B4 distance of 13 km somewhat exceeds the estimated length of the optical fibre link from the PCR to the remotest experiment area (CMS at Point 5), which it is planned to install during the course of 2000.

Round-trip tests with a co-sited transmitter and receiver allowed the jitter of the recovered clock at the receiver to be measured relative to the clock input to the transmitter. They also allowed the slow variations in the transmission path delay caused by temperature changes to be observed.

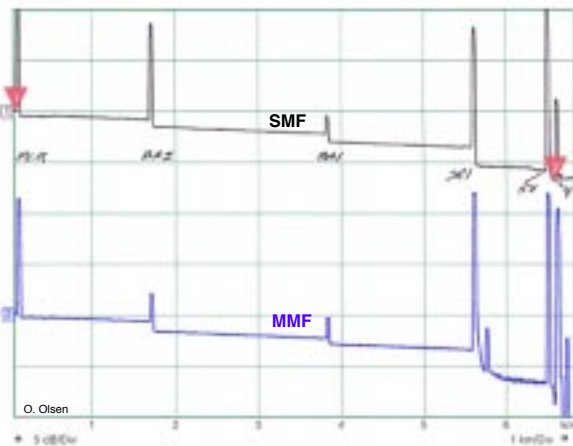

Figure 2: OTDR PCR - B4

Fig. 2 indicates the results of OTDR measurements on these fibres. The RD12 TTC system uses high-power Fabry-Perot lasers operating in multiple longitudinal modes, which are less sensitive to reflections than DFB types. Including the additional connector and patchcord losses at the PCR, the round-trip attenuations are about 17 dB and 23 dB for the singlemode and multimode fibres respectively.

Fig. 3 shows the performance of the multimode and singlemode fibres for the transmission of a 40.079 MHz square wave over the 13 km loop. In these tests the signal was received by a low-noise modular optoelectronic receiver since the use of a TTCrx would have masked the effects of fibre dispersion to some degree.

The jitter of the received signal was found to be about 11 ps rms over the singlemode fibre and 50 ps rms over the multimode fibre loop. The system operates at 1310 nm, at which the chromatic dispersion of the fibre is negligible for narrow spectrum laser sources.

Multimode fibre has been chosen for the distribution of the TTC signals at the experiments because the multimode dispersion is low over the short distances involved (typically less than 100m). Multimode optical tree couplers, which will be required in large numbers for these networks, are substantially cheaper (by a factor of about three) than equivalent singlemode devices and there

is also a certain cost advantage for other components such as optical fibre connectors and coupling bushings.

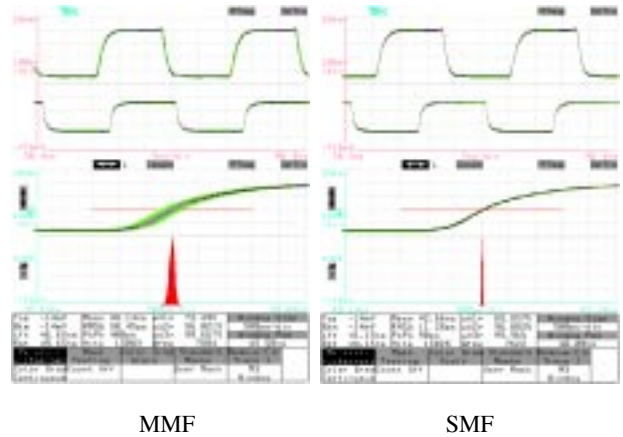

Figure 3: Bunch clock transmission over 13 km fibre

On the other hand for the longer links from the PCR transmitter to the LHC experiment areas the tests indicated that the improved performance of singlemode fibre is significant and since only a single 1x32 optical tree coupler is required at the transmitter its higher cost is less important.

#### IV. PCR TRANSMITTER

The optimum optical input signal level for the present versions of the PIN/Preamp and TTCrx is about -20 dBm. High signal levels may cause pulse width distortion, whereas low signal levels result in higher clock jitter and (although the actual rate is too low to be measured) a greater probability of error.

To cope with the attenuation of the longest links, the PCR transmitter has been designed to provide multiple outputs at a level of -3 dBm. This has been achieved using an OL364A-40 laser diode with a nominal output at 1310 nm of 40 mW (+16 dBm), feeding directly a 1x32 singlemode tree coupler with an insertion loss of 19 dB per port (15 dB splitting loss plus 4 dB excess loss). For stable operation and long life the laser temperature is regulated within  $\pm 0.1^\circ\text{C}$  by a 3-term controller.

The transmitter, which is a singlemode version of an initial development model that has already been supplied to several users, is shown in Fig. 4. The SPS orbit signal is only broadcast for the special LHC-structured SPS test beam runs. As the frequency of this signal swings about 29 Hz during acceleration, it is synchronized at the transmitter to avoid any metastability. Tests were carried out to verify that the signals transmitted by the coaxial cable links from the Faraday Cage are not perturbed by the ramping of the SPS magnets.

Using a new TTCtx compact laser transmitter module (described later), an additional 14 outputs can be provided from the present PCR transmitter crate should the need arise. Additional TTCtx modules can be housed in a second crate should further expansion become necessary at some future date. A maximum of 280 singlemode

outputs at 0 dBm could be supplied per crate. The optical power delivered to the TTCmi receiver at each experiment area is adjusted to the optimum level by inserting fixed singlemode optical attenuators of appropriate value.

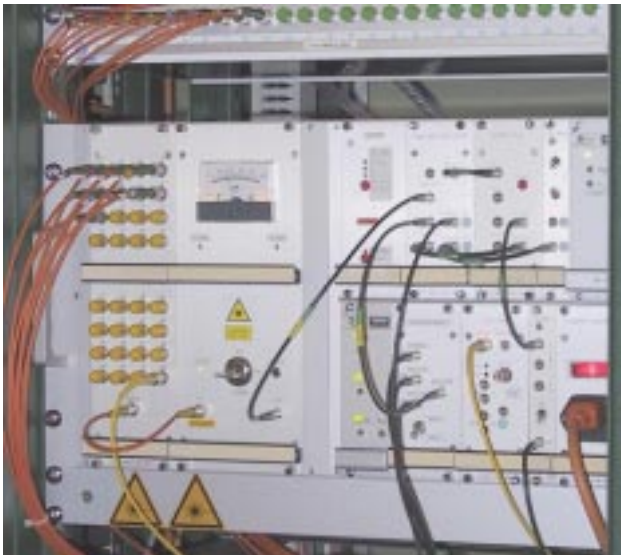

Figure 4: PCR transmitter

The PCR transmitter has been running continuously since February 2000. Because the correct functioning of the transmitter is necessary for the running of all the LHC experiments, a spare unit should be installed at a future date so that a backup is immediately available. There are sufficient outputs to drive duplicate fibre links from the PCR to each LHC experiment area if this redundancy is desired.

The transmitter crate incorporates an LHCrx module (described later) which provides facilities for monitoring either the encoded optical output signal or the bunch crossing and orbit clocks extracted from it. The optical fibre to Building 4 has been left in place so that at any time the output from the PCR transmitter can be monitored with the communications signal analyser there for diagnostic purposes.

## V. PHASE STABILITY

The initial set up of the deskew parameters in all the TTCrxs of each subdetector will be done from a database of computed delays and test pulse generator measurements. When LHC beams are available, the timing will be fine tuned by procedures such as crosscorrelation of the event occurrence pattern with the known LHC bunch structure, consecutive signal sample amplitude comparison or possibly online track fitting. These procedures can be implemented in automatic feedback control loops concurrently with normal data-taking [4].

Any slow variation in the phase of the 40.079 MHz clock delivered by the TTC system relative to the actual LHC bunch crossings will thus be automatically compensated for within these control loops. However, it

is very desirable that any such phase wander be as small as possible.

As a preliminary test of the phase stability of the transmitter and the long distribution fibre from the PCR, measurements were made at intervals during a period of a few days of continuous running via the 13 km loop. A repetitive pattern was observed in which the path delay varied between a minimum in the early morning and a maximum at the end of the afternoon. The total diurnal variation was less than 100 ps and no longer-term drift of the mean was observed.

This is a remarkably small variation. It is attributed to the fact that since the optical fibre is largely underground only small sections of it are subject to significant diurnal changes in temperature.

## VI. TTCMI MACHINE INTERFACE

In the initial phase, RD12 developed the system components required to broadcast TTC signals to the electronics controllers within a single trigger partition of an experiment. In this context a partition is defined as a distribution zone which, at least at times, must operate with Level-1 trigger accepts and other broadcast signals which differ from those in other zones. This implies that each partition has its own TTCvi [5], optical transmitter and fibre distribution network.

A TTC machine interface (TTCmi) [6] has been developed which receives the optical timing signals broadcast by the PCR transmitter and distributes the bunch clock and suitably phased orbit clock to the TTCvi modules and TTC transmitters for many such trigger partitions. The complete TTCmi is shown in Fig. 5.



Figure 5: TTCmi minicrate

A simplified block diagram of the TTCmi is shown in Fig. 6. It is based on the TTC minicrate which was supplied to many users during the development phase of the project, with the addition of a new LHCrx module and a variable number of TTCcf clocks fanout modules.

The development of the TTCmi was funded directly by equal contributions from the LHC collaborations and one TTCmi has been constructed for each experiment. It is also possible to upgrade a TTC transmitter minicrate to a TTCmi and this has been done for the CMS Tracker Group.

### A. LHCrx

The LHCrx replaces the simple Monitor Rx module in the TTC minicrate but it retains the optical signal monitor facility which is useful for diagnostic purposes.

It uses a TTCrx ASIC [7,8] to extract the bunch and orbit clocks from the encoded optical input and provides ECL outputs for further processing. The bunch clock output is an AC-coupled 40.079 MHz square wave while the orbit output is a DC-coupled negative-going pulse train of duration 1  $\mu$ s and period 88.924  $\mu$ s. These are the signal characteristics for which the transmitter encoder clock and TTCvi orbit input circuits were designed.

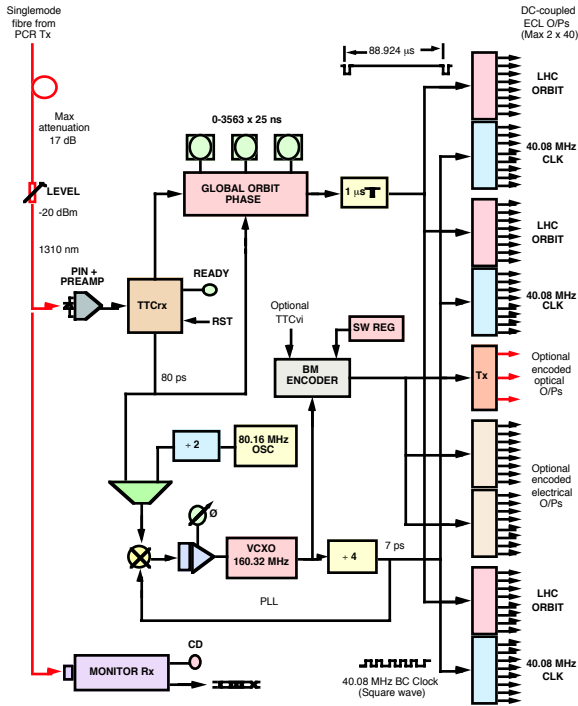
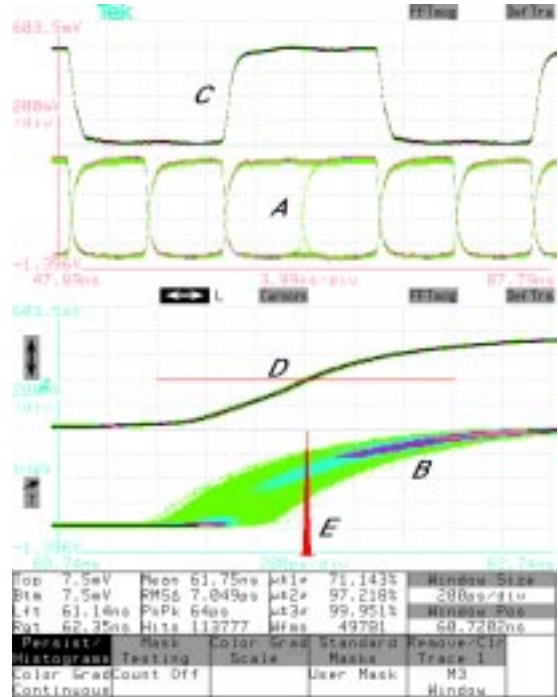

Figure 6: TTCmi block diagram

The TTCrx internal coarse deskew circuit provides for phase adjustment over a range of 16 bunch-crossing intervals (about 400 ns). This is sufficient to compensate for the differences in time-of-flight and optical fibre path length between different destinations at one experiment but not for the phase differences in the orbit signal received from the PCR at different points around the LHC ring.

The LHCrx incorporates a global digital phase adjustment for the orbit signal which allows it to be set throughout the 88.924  $\mu$ s period in 3564 steps of the bunch-crossing interval of about 25 ns. The master orbit signal phase is set by rotary switches inside the LHCrx which should not require adjustment after being set up for a particular experiment location.

The 40.079 MHz bunch clock output from the LHCrx has a jitter of about 80 ps rms, which is too high for the master clock for an LHC experiment. This signal is therefore used as the reference phase for a 160.316 MHz VCXO/PLL in the TTCmi. The VCXO has very low internal noise, which allows it to be used with a narrow loop bandwidth so that the output jitter is determined by the sub-harmonic feedthrough from the fundamental oscillator rather than the noise on the reference signal.



- Trace A:* Biphasic mark encoded output from PCR transmitter. The central transitions represent the LHC orbit signal, occurring once per 3564 bunch clock periods.
- Trace B:* 200 ps/div window on bunch clock recovered by the TTCrx.
- Trace C:* Recovered bunch clock after cleanup by PLL in TTCmi.
- Trace D:* 200 ps/div window on Trace C (40.079 MHz bunch clock).
- Histogram E:* Jitter of recovered bunch clock after PLL cleanup. (7 ps rms).

Figure 7: TTCmi performance (13 km fibre)

The  $\pm 4$  output from the VCXO, which has an rms jitter of about 7 ps, is the master 40.079 MHz clock which drives the TTC distribution systems of the experiment. This bunch clock, together with the master orbit clock, is distributed by short coaxial cables to the optical transmitters and TTCvi modules of each of the TTC partitions by TTCcf modules in the TTCmi.

Fig. 7 indicates the performance of the TTCmi when receiving the signal from the PCR transmitter via the 13 km fibre loop. Jitter measurements of the recovered clocks are relative to the clock input to the transmitter, which triggers the analyser.

## B. TTCcf

In order to choose the configuration of the electrical fanout of the bunch and orbit clocks from the TTCmi, the LHC experiment collaborations were asked to estimate the number of TTC partitions foreseen. The preliminary ATLAS model [9] has a total of 35 partitions and CMS currently foresees about 32. To allow some spares the TTCmi was designed to provide over 40 outputs each of

the bunch and orbit clocks when it is equipped with 5 TTCcf modules.

Each TTCcf module comprises two independent 1x9 sections, one of which would normally be used for the bunch clock and the other for the orbit clock fanout. In some experiments, such as LHCb, there is a need in the control room to supply more equipment with the bunch clock than the orbit clock. Both sections of each TTCcf have DC-coupled ECL inputs and outputs and they can be used interchangeably for either signal to match such a requirement.

It is expected that for trigger latency reasons the TTC transmitters for all the partitions will be grouped together in the vicinity of the central trigger processor so that the coaxial cables by which they receive the clock signals from the TTCmi will be short. For longer distances low-loss coaxial must be used with adapters, rather than the miniature solid dielectric type.

### C. TTCmx

For even longer distance transmission, or where ground offsets are troublesome, TTCmx laser transmitters can be plugged into the TTCmi crate in place of some of the TTCcf modules.



Figure 8: TTCmx laser transmitter

The TTCmx module (see Fig. 8) provides 4 optical outputs at a level of 0 dBm, each of which can be fanned out by a 1x32 tree coupler to broadcast to a total of 128 destinations. A low-jitter electrical output is provided to allow TTCmx modules to be daisy-chained to broadcast to larger partitions. The transmitters can be used to send either the 40.079 MHz bunch clock alone, or the composite encoded TTC signal. In the latter case a TTCrx with PIN/Preamp is required at the receiving end.

The TTCmx uses multi-sourced InGaAsP low-threshold MQW hermetic-package Fabry-Perot lasers with temperature-compensated bias current and automatic power control by rear facet monitor.

## VII. OPTICAL TREE COUPLERS

Fused biconic taper (FBT) fabrication remains the technology of choice for optical tree couplers for TTC distribution networks. Although bare couplers can be integrated in custom detector electronics and used for inter-module distribution within crates, additional protective packaging is required for mounting them in standard distribution racks.

A number of enclosures for optical tree couplers have been developed. Fig. 9 shows a 1x32 coupler mounted in a 1U rack tray. Industrial cable breakout enclosures of this size generally provide for 24 outputs.

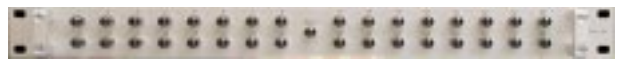

Figure 9: 1x32 multimode optical tree coupler



Figure 10: Cassette-mounted 1x32 singlemode tree coupler

Fig. 10 shows the cassette enclosure which was developed for the singlemode 1x32 coupler for the PCR transmitter. Whereas 1x32 multimode couplers can be created in a single fusion, the maximum fanout possible with singlemode fibre is 1x4. Accordingly this 1x32 coupler is formed of a tree composed of eight 1x4 couplers spliced to two intermediate 1x4 couplers fed by one 1x2 coupler at the root.

The assembly of such a configuration is quite delicate but the finished packaged coupler is robust. The total spread in the optical output power delivered by the 32 ports is less than 1.9 dB.

## VIII. LASER TRANSMITTERS

In addition to the TTCmx, two new types of laser transmitter module have been developed by RD12 for TTC signal distribution at the experiments [10]. The modules are single-width 6U VME size and use only standard VMEbus power supplies. They can be employed separately or in combination to match the requirements of a variety of different TTC distribution architectures.

The TTCex module provides 10 optical outputs at a level of 0 dBm, each of which can be fanned out by a

1x32 optical tree coupler to broadcast to a total of 320 destinations. The module contains 2 biphasic mark encoders driven by a common internal VCXO/PLL with very low jitter. It can be operated as a single unit, or in independent halves to feed 2 small partitions of up to 160 destinations each. Outputs from the encoders are provided to drive extension TTCtx modules for larger partitions, or a readout supervisor switch (LHCb).



Figure 11: TTCex and TTCtx laser transmitters

The TTCtx module is similar to the TTCex but has 14 optical outputs instead of 10 and does not contain any encoders. It can be operated in independent halves to feed 2 small partitions of up to 224 destinations each, or as a single unit to feed a total of 448 destinations. An electrical output is provided to allow several TTCtx modules to be daisy-chained to broadcast to even larger partitions. Since TTCtx modules do not contain encoders they must be driven by a TTCex module (or by the encoder in a TTCmi, TTC minicrate, TTC high power transmitter crate, TTCvx, or the output of a readout supervisor switch).

TTCex, TTCtx and TTCmx modules are Class 1 laser products per CDRH 21 CFR 1040 and IEC 60825 [11], and they are ITU-T G.957 compliant except for the higher mean launched power. They are equipped with a manual disable switch, laser emission indicator and warning labels and external interlock for the VMEbus modules is possible through the SYSFAIL line.

## IX. LHC BEAM INSTRUMENTATION

For the LHC beam instrumentation the machine timing signals and synchronous commands must be broadcast to several hundred front-end equipment and beam

instrumentation control crates [12]. There are 24 primary BI nodes around the ring, located at the 8 access points plus 16 alcoves.

Tests are currently being conducted by CERN SL/BI Group [13] to determine whether the system which has been installed for distributing the LHC machine timing to the experiments can also be used for this purpose. Apart from the cost saving there could be operational and maintenance advantages in having a single CERN-wide system for the distribution of the same timing signals.

## X. ACKNOWLEDGEMENT

RD12 would like to acknowledge the excellent cooperation and support received from members of CERN SL Division. In particular the contributions of G. Beetham, L.K. de Jonge and O. Olsen of SL/CO Group, Ph. Baudrenghien of SL/HRF Group and J.-J. Savioz of SL/BI Group have been invaluable to the project.

## XI. REFERENCES

- [1] Taylor, B.G., "TTC Distribution for LHC Detectors", IEEE Trans. Nuclear Science, Vol. 45, June 1998, pp. 821-828.
- [2] RD12 website: <http://www.cern.ch/TTC/intro.html>
- [3] Marinelli, N. et al, "The CMS Tracker front-end and control electronics in an LHC-like beam test", these Proceedings.
- [4] Varela, J., "Timing and Synchronization in the LHC Experiments", these Proceedings.
- [5] Farhouat, P. and Gällnö, P., "TTC-VMEbus Interface (TTCvi)", RD12 working document, CERN.
- [6] Taylor, B.G., "TTC machine interface (TTCmi) User Manual", RD12 working document, CERN.
- [7] Christiansen, J., Marchioro, A., Moreira, P. and Toifl, T., "TTCrx Reference Manual - A Timing, Trigger and Control Distribution Receiver ASIC for LHC Detectors", RD12 working document, CERN.
- [8] Toifl, T. et al, "Measurements of Radiation Effects on the Timing, Trigger and Control Receiver (TTCrx) ASIC", these Proceedings.
- [9] Status Report on the RD-12 Project, CERN/LHCC 2000-002, 3 January 2000.
- [10] Taylor, B.G., "Laser transmitter modules for TTC distribution at the LHC experiments", RD12 working document, CERN.
- [11] "Safety of laser products - Part 2: Safety of optical fibre communications systems", IEC 60825-2, 1993-09.
- [12] Rausch, R., "Electronic Components and Systems for the Control of the LHC Machine", these Proceedings.
- [13] Savioz, J.-J., Private communication.