

Design Considerations of Low Voltage DC Power Distribution for CMS Sub-Detectors

Allongue¹, B.; Elias², J.; Fontaine¹, P.; Lusin³, S.; Rivetta⁴, C.; Robl³, P.; Stefanini¹, G.; Szoncsó¹, F.

¹CERN, 1211 Geneva 23, Switzerland

²Fermilab, Batavia, U.S.A.

³University of Wisconsin, Madison, U.S.A.

⁴ETH Zurich / CERN 1211 Geneva 23, Switzerland

Claudio.Rivetta@cern.ch

Abstract

A distinguish feature of LHC detectors is the enormous number of front-end electronics (FE) channels in all of the sub-detectors. Low-voltage power supply systems in the range of multi-kilowatts are required to bias such electronics read-outs. Several configurations has been proposed and analysed by the different groups showing particular advantages and disadvantages. For the CMS detector, the Hadronic Calorimeter (HCAL) and the Muon End-caps (EMU) have proposed a DC power distribution system based on DC-DC power switching converters located in the cavern near the FE.

The main advantage of this topology is the reduction in volume of the distribution cables due to the relative low primary currents. Locating the DC-DC converters in the hostile environment of the detector cavern is a disadvantage due to the presence of magnetic field and radiation. In this paper, guidelines for the system design and selection of the components are presented. Additionally, some tests conducted to validate the application of commercial units are reported and future tests are described.

I. INTRODUCTION

HCAL front-end electronics is located in the barrel and end-cap parts of the CMS Hadronic Calorimeter. EMU electronics is located on the eight end-cap wheels of the detector.

Low voltage has to be distributed to those areas of the detector to power-up the FE. The topology proposed for the DC power distribution consists of AC/DC converters, located in the control room, that rectify the three phase mains and generate the primary 300 VDC voltage. Each rectifier supplies several DC-DC converters located in the cavern near the FE. The switching regulators convert the high voltage into appropriated low voltages that are locally distributed to the detector read-outs. Local regulation is performed in the FE at the board level using special linear low-dropout voltage regulators developed by CERN RD-49 collaboration.

In this paper the system description and requirements are presented in sections II and III. In section IV, general design considerations are evaluated, and in section V is presented radiation test result performed on several DC-DC converter units.

II. SYSTEM REQUIREMENTS

The HCAL front-end electronics requires four different voltages at board level, they are +5.5V analog voltage and +3.3V and +2.5V digital voltages. Special designed low-dropout regulators [1] are used at each board to regulate the bias voltage for six channels. Performance tests over those regulators have proved they can resist without problem the radiation level around the read-out boxes and also reject line differential perturbations at relatively high frequency. They allow including features as maximum current protection, powering disable per board via a digital signal, etc. All these characteristics make the design of the link between the DC-DC converters and the FE read-out boxes relatively simple because it is not necessary to use remote sensing.

Distribution buses inside the read-out box power up each board. The voltages supplied are +4.3V for the digital part and +6.5V for the analog one. The expected nominal current per box for the analog section is 16.5A and for the digital section 11.5A. The total power required by the HCAL FE is about 17KW. Assuming a voltage drop of about 1V at maximum current over the output distribution cables, the voltages required at the output of the switching converters are +5.3V and +7.5V.

III. SYSTEM DESCRIPTION

A part of the topology of the DC power distribution is depicted in fig. 1. AC/DC converters rectify the three phase AC mains and generate DC high voltage that is carried out from the control room to the detector cavern. DC/DC converters transform the high voltage into the required low-voltage with high efficiency. The low-voltage is distributed a short distance, inside the detector, to the read-out electronics. For the HCAL sub-detector

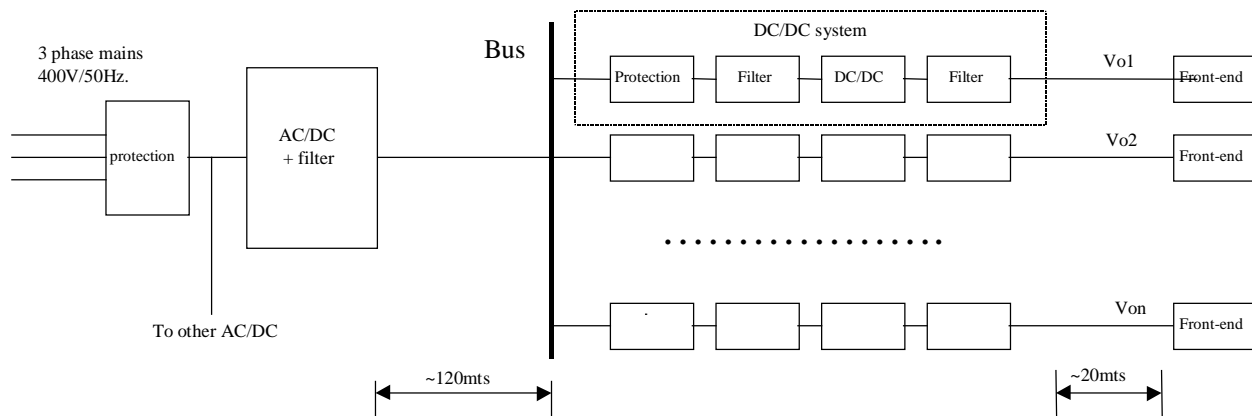

Figure 1: DC distribution system

the DC-DC converters will be located on the wheel periphery for the barrel (HB), disk 1 and -1 for the end-cap (HE) and for the forward calorimeter (HF) in racks near to the FE. EMU sub-detector will distribute the converters around end-cap disks.

Modularity of the DC-DC converter is the primary requirement. It will facilitate replacement of failed units during short-period scheduled access to the cavern providing a reduction in the time that a part of the sub-detector is down. Thus, each modular unit will include not only the basic power converters to attain the required output low-voltages but also protection, filtering, monitoring system and interface for remote operation.

The tendency is to use commercial units (COTS) in this design but it is difficult to satisfy all the requirements with such units. Instead, 'semi-custom' design has been used based on COTS with the collaboration of manufactures, assembly companies and the universities and laboratories involved. In addition, some custom designs are being evaluated. The DC-DC converters under test are produced by MELCHER, DELTA and CNB electronics. These commercial units include EMI filtering and output over-voltage protections in some cases. Also, VICOR converters have been tested. They do not include any EMI filtering and over-voltage protections.

IV. DESIGN CONSIDERATIONS

A. Thermal Considerations

Switching power converters have high efficiency. In general the units tested operated with an efficiency of about 80%. Two DC-DC converters and additional filtering and protections compose each DC-DC system (Fig. 1). The power dissipated on each DC-DC system is about 65W at maximum output power. The heat is removed from the units using a water cooling system. The goal in this design is to be able of removing the DC-DC system without disconnecting the cooling system. This condition allows a simple and reliable change of units but

introduces some limitation in the heat transference between the DC-DC converters and the cooling plate. AC/DC converters also exhibit high efficiency, in the range of 80-90%. A conventional forced air cooling system is planned for these converters.

B. System Reliability.

An important issue in the design of the DC power distribution system is the overall reliability. In this particular topology, part of the equipment is located in the control room where the radiation level and magnetic field is negligible and the access for replacement of faulted units is almost immediate. There are parts exposed to neutron radiation and magnetic fields with access for replacement that can be relatively short as one week or up to very long periods as one year. To improve the up-time of the system, a modular design is important for parts located in areas where the access time is relatively short. As it was mentioned before, AC-DC and DC-DC converter units have to be designed putting special effort in the modularity and simple replacement.

Three types of part failures take place within the lifetime of electronic equipment: quality defect failures, reliability failures, and wear-out failures. The reliability failure induced by electrical and thermal stresses is the most important cause of failure. During the useful life period of electronic equipment, the failure density function obeys Poisson process.

The system reliability is influenced not only by the parameter *Mean time between failure* (MTBF) of each unit but also by the topology. In this design, the number of DC-DC converters per rectifier, n , and the number of AC-DC converters, m , affect the total reliability. A factor of merit of the system that characterises the reliability is the *limiting availability* A , defined as the probability the complete system is functioning in the long term. This magnitude can be estimated considering the time failure of the complete system follows a stochastic process with the Markov property.

A simple model for a part of the system containing one AC-DC converter and n DC-DC systems is shown in

figure 2. It assumes stationary transition probabilities. Poisson point process follows these properties.[2]

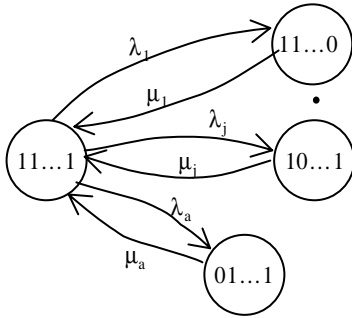

Figure 2: Reliability model

The state 11..1 corresponds to the case the complete system is ON, the state 01...1 corresponds to the case of failure of the AC-DC converter, while states 10..1, 11...0 correspond to the failure of one of the DC-DC system. The parameter $\lambda=1/MTBF$ is the failure rate and μ the repair rate. Assuming the sub-systems are equals and statistically independent, the availability of the total system is:

$$A = \frac{1}{1 + n \cdot m \frac{\lambda}{\mu} + m \frac{\lambda_a}{\mu_a}}$$

All this figures of merit depend on the component parameter but also on both n and m . Assigning an availability of 0.999 for the complete system and having $n=10$ DC-DC converter per AC-DC converter, $\lambda = 200 \times 10^{-9} \text{ hrs}^{-1}$ is required for the DC-DC converters and $\lambda_a = 3000 \times 10^{-9} \text{ hrs}^{-1}$ for the AC-DC converter units. An important conclusion of this simplified analysis is the MTBF assigned to the DC-DC converter unit must include the effect of additional components as filters and protections. Also, the MFBT has to take in consideration the converter will operate in a radioactive environment with high energy neutrons capable of inducing Single Event Burnt-out in the high voltage power devices.

C. Electromagnetic Compatibility

Switching power supplies, in general, generate more noise than equivalent linear power supplies. In this design is very important to keep the noise up to a level that does not compromise the operation and performance of the FE and neighbour systems. [3] The EMC standards recommended for emission is the EN55011-22 for conducted and radiated noise and the EN 60555-2 for low frequency harmonics. Available DC-DC converters have to pass these EMC standards to become a commercial product. Some companies, as VICOR, produce what is called 'building blocks'. Such DC-DC converters are not required to pass EMC tests because they are considered to be just part of a final product. For these units, input and output filters are necessary to mitigate the common-mode and differential-mode noise.

The noise generated by DC-DC converters depends strongly on the topology of the converter, layout design

and how the active devices switch. New generation of converters use soft switching commutation to increase the switching frequency and reduce the size. These converters generate almost an order of magnitude less noise than units that employ hard commutation.

VICOR blocks a characterized by soft switch commutation. These blocks have only an input and output differential filter to reduce harmonics. A first noise measurement on these units using a current transformer and a spectrum analyser revealed the conductive noise is superior to the level recommended by the norm EN 55011-22. In this measure, the magnitude of the positive terminal input current is higher than the specification in the range of frequency between 150KHz to 3 MHz. This current present typical 'spikes' at about 500 Khz (switching frequency) and its harmonics. Also the measurement of the common-mode current reveals that the 'background' noise present in the input current is due to common-mode components. In this mode appears very attenuated the spikes at the switching frequency and harmonics.

The design of the input and output filter to mitigate common-mode and differential-mode noise is better carried out analysing the noise reduction required on each mode [4]. From the previous measurement, it is necessary to suppress common-mode components at the input, in the range between 150KHz and 3MHz and differential mode corresponding to the lower harmonics of the switching frequency. Similar criterion can be used for the output filter. Additional measurements are necessary in this unit and other DC-DC converters in a higher frequency range to understand the noise radiated by both the input and output cables.

Commercial filters are implemented with different level of attenuation for both modes. These filters cover the range of frequencies between 150KHz and 30MHz. If filtering is necessary at lower frequencies, they could adversely interact with the converter, resulting in severe performance degradation or even instability. The design of these filters has to consider not only the attenuation specification but also the interaction with the converter.

D. System stability.

DC-DC switching converters with tight output voltage regulation operate as constant power load. In such cases, the instantaneous value of the input impedance is positive, but the incremental input impedance is negative. Due to the negative impedance characteristic of switching regulators, interaction between those units and other parts of the system may result in system instability. This destabilising effect is known as negative impedance instability. In order to assess stability and performance, large-signal and small-signal models can be used. Small signal models allow a more simple analysis, but solutions are only local, in the sense they are valid around the operating point where the linearized model was developed.

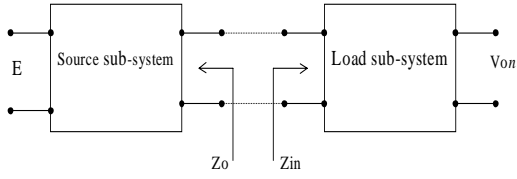

Figure 3: Block diagram

Following a linear model, the system can be represented in a block diagram at the bus as is depicted in figure 3. The source sub-system contains the impedance of the AC mains, the AC/DC converter and the HV distribution cable. The load sub-system is composed by n DC-DC converters connected at the input in parallel to the bus and feeding at the output individual loads (FE). The source sub-system is stable when operates alone loaded by a regular impedance. The same assumption is valid for each DC-DC switching converter. Assuming the source sub-system has an input to output (I/O) transfer function F_s and each converter an I/O transference function F_c , the overall I/O transference of the complete system is:

$$F_{sc} = \frac{V_{on}}{E} = \frac{F_s \cdot F_c}{1 + \frac{Z_o}{Z_{in}}} = \frac{F_s \cdot F_c}{1 + T_m}$$

where Z_o is the output impedance of the source sub-system and Z_{in} is the input impedance of the load sub-system. Due to both F_s and F_c are stable transference functions, the stability of the whole system is defined by the factor $1/(1+T_m)$ that represent the loading effect between source and load sub-system.

If $|Z_{in}| \gg |Z_o|$ for all the frequencies, then the loading affect is negligible and the stability of the system is assured if each sub-system is stable. However, in many systems it is often impossible to keep such a relation at all the interfaces and in the complete frequency range. When $|Z_o|$ is larger than $|Z_{in}|$, a considerable loading effect exist. It does not necessarily imply a stability problem. In this case, the Nyquist criterion can be applied to the loop gain T_m to determine the system stability [4].

Let us consider the system implemented with DC-DC Vicor converters. Figure 4 depicts both impedances Z_o and Z_{in} of the proposed system calculated using an analytical model for each sub-system. Z_{in} corresponds to ten similar converters connected in parallel to the HV bus. It does not include any filter or interface to reduce both the EMI and conducted noise. It is possible to observe there are two frequency intervals where $|Z_o| > |Z_{in}|$. Since $|T_m|$ crosses the 0dB line twice, it is necessary to analyse the phase margin to determine the system stability. At point A, the phase margin is negative showing instabilities at low frequency due to the interaction between the AC/DC converter output filter and the switching converters. At point B, the phase margin is positive but less than 60° . The system is stable at that frequency but the voltage at the bus will exhibit poorly damped oscillations. In this case, it is necessary to

increase the dumping in high frequencies and, at low frequencies, to improve the output impedance of the AC/DC converter to obtain a satisfactory system.

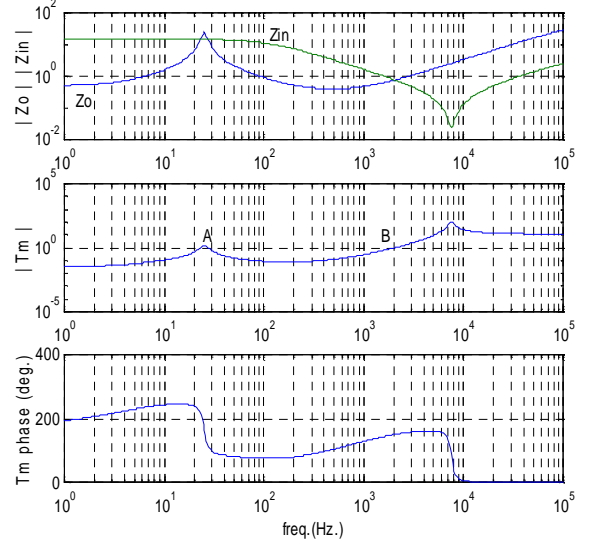

Figure 4: Bode Plot of T_m

This analysis allows defining phase margins and gain margins to design a stable system with good performance. The definition of the load impedance margins is useful for the design of filters or interface network to include between the bus and the individual converters. As it was presented above, these filters not only have to be designed to achieve the noise specifications but also they do not have to affect the system stability [6]. Furthermore, the specification of the output filter of the AC/DC converter and the HV line can be verified using similar analysis.

V. VALIDATION TESTS

The level of radiation and the magnitude of the magnetic field into the CMS cavern and different parts of the detector have been analysed and calculated using simulation programs [7] [8]. Based on this information, the level of radiation is lower than 1Krad and neutron fluence lower than 6×10^{10} N/cm² in the area where the power supplies are located. The magnetic field presents maximum dispersion between the wheels and the disks, with maximum absolute values reaching up to 0.32 T (3200 Gauss). The converters have to operate under these hostile conditions during 10 years.

E. Radiation Tests

One important stage of this design is find suitable units that can operate in environments with radiation. The idea is to characterize the radiation tolerance of candidate converters and analyse, in case of failure, critical components to be replaced in the prototypes. Several radiation tests have been conducted and new one are under evaluation. These tests include total dose, displacement and single event effects (SEE).

Displacement effects due to radiation on power converters have been evaluated using a low energy neutron reactor at the *Commissariat d'Énergie Atomique (CEA), Dijon, France*. The total fluence applied in all the tests was greater than that expected in 10 years of continuous operation. During the test, the DC-DC converters operated in nominal conditions. The only effect measured due the neutron fluence applied was a small deviation of the output voltage. The drift was in the order of tens of millivolts. Table 1 summarises the results of radiation tests with low-energy neutrons.

Table 1: Low Energy Neutron Radiation (1MeV eq.)

DC-DC conv.	Fluence	Results
MELCHER	10^{12}N/cm^2	mV drift output voltage
DELTA	10^{12}N/cm^2	mV drift output voltage
VICOR	3.10^{11}N/cm^2	mV drift output voltage

An important remark is DELTA and MELCHER units have failed similar tests before. These units have an opto-coupled in the closed loop feedback to keep the galvanic isolation of the converter. The replacement of this critical device by one manufactured by HP proved to be an effective solution.

Due the total dose is very low in the periphery of the detector, a test that is very important to validate the operation of converters in neutron radiation environments is the tolerance to single events effects (SEE). The energy spectrum in that area is relatively high in the range of energy between 60MeV and 200MeV. The idea is to test on power devices Single Event Burn-out (SEB) and Single Event Gate Rupture (SEGR) and induced 'glitches' or Single Event Up-set (SEU) in the control circuit that can produce a permanent failure in the power devices. In this way, a destructive test of several power supplies was performed at *Université Catholique de Louvain-la-Neuve, Centre de Recherches du Cyclotron, Belgium*, using a 60 MeV proton beam. The test consisted in radiating different critical areas of the power supply up to a fluence level representative of the detector area without compromising the total dose. Table 2 summarises the results of the first radiation campaign.

Table 2: 60Mev Proton Radiation

DC-DC conv.	Fluence	Results
MELCHER	$1.5 \times 10^{10} \text{ p/cm}^2$	Passed
DELTA	$0.33 \times 10^{10} \text{ p/cm}^2$	Failed, Input Circuit
CNB	$1.5 \times 10^{10} \text{ p/cm}^2$	Passed

New tests, destructive and non-destructive, are under preparation in collaboration with Atlas sub-detectors and CERN EP-ESS group. Based on SEB and SEGR tests, it is possible to define possible solutions to include into the final power supplies. It can be replacing the power device by either a de-rated device or SEE tolerant devices.

F. Magnetic Shielding

DC/DC converters have to operate under a continuous magnetic field. The magnitude of the magnetic field can reach values up to 0.32 T in some areas of the periphery. The maximum external magnetic field that can be tolerated by commercial converters under nominal operation is between 10-30 mT. It depends of the converter and the direction in which the magnetic field is applied. Appropriated shielding is necessary for a safe operation of the converter in such conditions. Preliminary calculations have shown the thickness of the magnetic shield have to be in the order of 2-3 cm to have acceptable attenuation of magnetic fields densities of 0.4T. Further analysis is necessary to understand better the location of the DC-DC converter and improve the design of the magnetic shield.

VI. CONCLUSIONS

Guidelines for the design of DC distribution system have been presented. They take into account in the design stage factors as reliability, filtering and stability of the complete system. Another important points as protections and monitoring can be included in these initial considerations. Due to part of the system operates in a hostile environment results of radiation test have been presented.

References

- [1]http://rd49.web.cern.ch/RD49/VoltReg/L4913_Speccs_10Aug2000.pdf
- [2] Hoyland A, Rausand M. 'System Reliability Theory' 1994, ISBN 0-471-59397-4
- [3] Szoncsó, F. 'EMC in High Energy Physics' <http://s.home.cern.ch/s/szoncsó/www/EMC/>
- [4] Paul, C.R, 'Introduction to Electromagnetic Compatibility' 1992, ISBN 0-471-54927-4
- [5] C. Wildrick *et.al.* "A method of defining the load impedance specification for a Stable Distributed Power System" IEEE Trans. on Power Electronics, Vol.10, No 3 pp 280-285. May 1995
- [6] Choi, B. Cho, B. "Intermediate Line Filter Design to Meet Both Impedance Compatibility and EMI Specifications" IEEE Trans. on Power Electronics, Vol.10, No 5 pp 583-588. September 1995.
- [7] Magnetic field Maps. http://edms02.cern.ch/tmpfiles/edms_tmp_435745_read_me_first.html
- [8] A global radiation test plan for CMS electronics in HCAL, Muons and experimental Hall. <http://cmsdoc.cern.ch/~faccio/proced.pdf>