

A Simplified and Accurate Front-End Electronics Chain for Timing RPCs

Blanco A.^(1,2), Carolino N.⁽¹⁾, Fonte P.^(1,3,*), Gobbi A.⁽⁴⁾
(for the ALICE Collaboration)

¹ LIP, Departamento de Física da Universidade de Coimbra, Portugal.

² GENP, Universidade de Santiago de Compostela, Espanha

³ ISEC, Quinta da Nora, Coimbra, Portugal.

⁴ GSI, Darmstadt, Germany.

Abstract

Recent advances in electronics and counter construction techniques have pushed the timing resolution of Resistive Plate Chambers below 50 ps σ , with a detection efficiency of 99% for MIPs. In this paper we describe a new front end electronic chain for accurate time and charge measurement, built in view of a possible application in ALICE's T_0 counter.

The circuit includes a fast (2.5 GHz) two-stage amplifier based on MMICs that feeds a fixed threshold discriminator followed by an external TDC. The amplified signal is also buffered into an external ADC for charge digitisation. All components are commercially available and their number is rather reduced.

The system was tested with realistic detector-generated test signals, yielding a timing resolution around 10 ps σ for signal charges above 100 fC and a charge resolution of 3.2 fC.

I. INTRODUCTION

The recent developments of timing Resistive Plate Chambers (RPCs) opened the possibility to build large high-resolution TOF arrays at a low cost per channel. Previous work reached a timing accuracy below 50 ps σ at 99% efficiency for single four-gap chambers [1] and an average timing accuracy of 88 ps σ at and average efficiency of 97% for a 32 channel system [2]. It was shown that each amplifying gap, of just 0,2 or 0,3 mm thickness, has a detection efficiency of 75% and that the avalanche develops under the influence of a strong space charge effect [3]. A Monte-Carlo model of the avalanche development reproduced well the observed data, confirming the dominant role of space charge effects in these detectors [4].

In this paper we describe a new, streamlined, front-end electronics chain for accurate time and charge measurement in timing RPCs. The circuit was used in developments aimed to extend the admissible detector area per readout channel and to include a position sensitive readout, in view of a possible application in ALICE's T_0 counter

The circuit is made uniquely of commercially available and inexpensive integrated circuits, featuring a reduced number of components. It includes a fast (2.5 GHz

bandwidth) two-stage amplifier that feeds a fixed threshold discriminator followed by an external TDC. The amplified signal is buffered into an external ADC for charge digitisation.

II. INPUT SIGNAL

The theory of parallel-plate gaseous detectors (see for instance [5]) states that a passing ionising particle will liberate N_0 electrons, creating an initial current, $i_0 = eN_0v/g$, that depends on the electron's drift velocity v and on the width g of the gas gap. The gas avalanche process will immediately amplify the initial current in time as (for sufficiently short times)

$$i = i_0 e^{st} h(t), \quad (1)$$

where s is a real positive parameter and $h(t)$ the unit step function. The exponential multiplication factor may reach very large values, up to 10^8 .

The output signal arising from the input current given by Eq. 1 can be calculated by noting (see for instance [6]) that the impulse response of a linear circuit can always be written as

$$y(t) = \sum_{j=1}^{N_p} k_j e^{\mathbf{a}_j t} h(t), \quad (2)$$

where N_p is the number of circuit poles and \mathbf{a}_j the complex frequency of each pole (stable circuits have $Re(\mathbf{a}_j) < 0$). The output voltage will be given by the convolution integral

$$v(t) = \int_0^t y(u) i(t-u) du = \quad (3)$$

$$= i_0 \left(\sum_{j=1}^{N_p} \frac{-k_j}{s - \mathbf{a}_j} e^{\mathbf{a}_j t} \right) h(t) + i_0 \left(\sum_{j=1}^{N_p} \frac{k_j}{s - \mathbf{a}_j} \right) e^{st} h(t)$$

Since $Re(\mathbf{a}_j) < 0$ the first term should remain small and vanish with time, allowing the second term, driven by the exponentially growing input current, to dominate by many orders of magnitude:

$$v(t) \approx i_0 Z(s) e^{st}. \quad (3)$$

* Corresponding author: fonte@lipc.fis.uc.pt

This feature, if true, would have important practical consequences because it would imply that the nature of the detector electrodes, coupling lines, amplifiers, etc. will affect only the magnitude of the output signal through the combined transimpedance $Z(s)$, while leaving unaffected the time development of the signal. The signal shape (exponential) will be influenced only by the value of s , determined by the gas avalanche process in the detector.

In order to experimentally verify Eq. 3 we note that, if two discriminators set at different threshold voltages, Th_1 and Th_2 , will sense the same output signal (as given by Eq. 3) one should have

$$Th_1 = v_0(s) e^{st_1}, \quad Th_2 = v_0(s) e^{st_2},$$

and

$$\ln(Th_1 / Th_2) = s(t_1 - t_2). \quad (4)$$

This relation has two experimentally verifiable properties: it states that $\ln(Th_1 / Th_2)$ should depend linearly on $t_1 - t_2$ with a proportionality constant s and that $t_1 - t_2$, for a given threshold setting, should be independent of i_0 (which fluctuates event by event) and independent of the circuit properties (summarised in $Z(s)$).

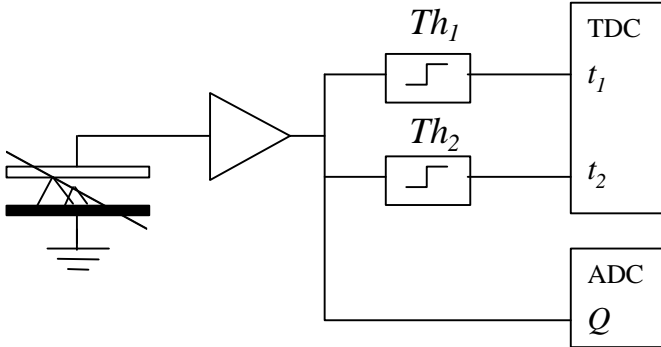

Figure 1: Principle of measurement of the preamplifier's output signal shape (Eq. 3).

The experimental data which can be seen in Figure 2, are obtained using a 0.3 mm gap timing RPC irradiated by an high energy pion beam. A very accurate logarithmic dependence is evident in Figure 2a, in excellent agreement with Eq. 4. An exponential fit to the data yields a value $s=8.9$ GHz. In Figure 2b one can see that the time difference is essentially independent of the final avalanche charge Q (assumed to be proportional to i_0), for not too small avalanches, also in agreement with Eq. 4.

III. CIRCUIT DESIGN

Since the input signal has frequency components extending up to the GHz range we have selected, following earlier applications [7], integrated amplifiers whose bandwidth extends up to this range (MMICs).

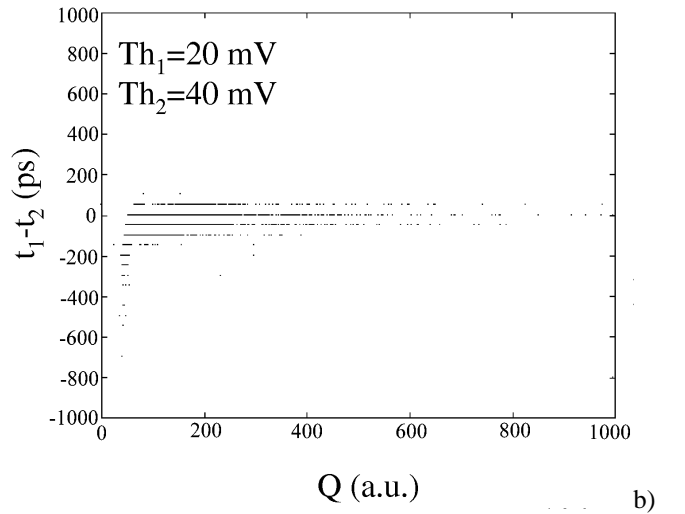
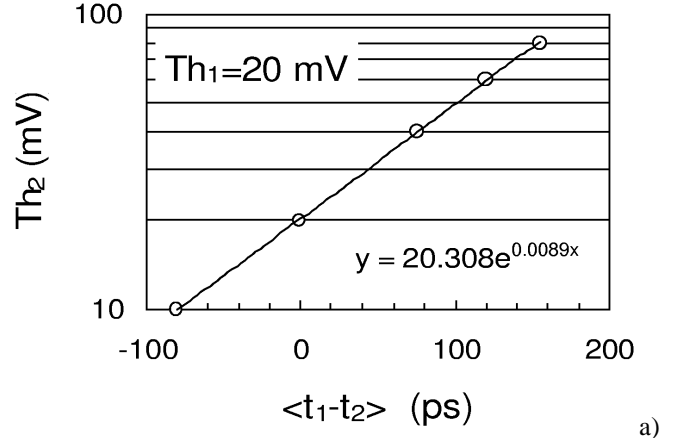

Figure 2: a) Average time difference between both discriminators for a given value of Th_2 and fixed Th_1 . The logarithmic dependence predicted in Eq. 4 is quite exactly confirmed and a fit to the data yields a value of $s=8.9$ GHz. b) Correlation plot between $t_1 - t_2$ and the signal charge Q . It is clear that these quantities are largely independent, in agreement with Eq. 4.

The preamplifier (Figure 3) was based on the Agilent chip INA-51063, featuring a 2.5 GHz bandwidth, 20 dB power gain and a 3 dB noise figure. The 50 Ω input impedance has proven to be quite convenient, allowing the input connection to be made through a standard cable and being sufficiently low to reasonably match the detector impedance.

The preamplifier was followed by an amplifier based on the Agilent MSA-0786 chip (3 GHz bandwidth, 12 dB power gain) that fed an AD9696 fast TTL comparator (see Figures 4 and 5). The amplified signal is externally accessible through a MAX4178 buffer for monitoring and charge measurement purposes. After an optional TTL delay line (NEWPORT 42A5251), convenient for signal synchronisation, the TTL signal is converted to the fast-NIM standard and sent to a TDC.

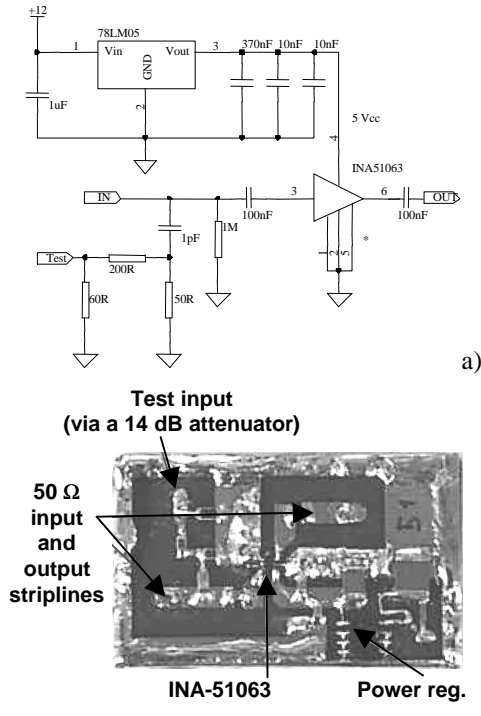

Figure 3: Schematic drawing a) and PCB layout b) of the preamplifier.

IV. TEST SETUP

The test set-up (Figure 6) included a single-gap RPC (with a measured capacity of 10 pF) illuminated by a ^{90}Sr radioactive source, as a realistic signal generator, feeding in parallel two front-end circuits. The time difference between both channels was measured by a TDC constituted by an ORTEC 286 TAC followed by a shaping amplifier whose output was digitised by a LeCroy 2249B peak-sensing ADC. The amplifier gain was adjusted such that the TDC had a 3 ps bin width and a 6 ns timing range. The measured time resolution of the TDC was $3.5 \text{ ps } \sigma$.

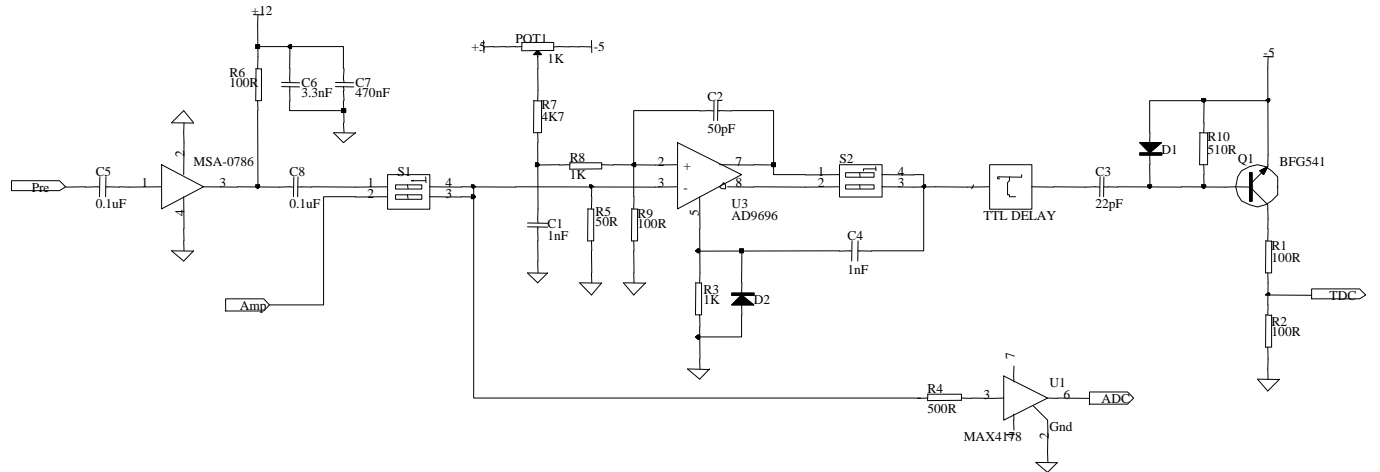

Figure 5: Schematic drawing of the amplifier-discriminator board.

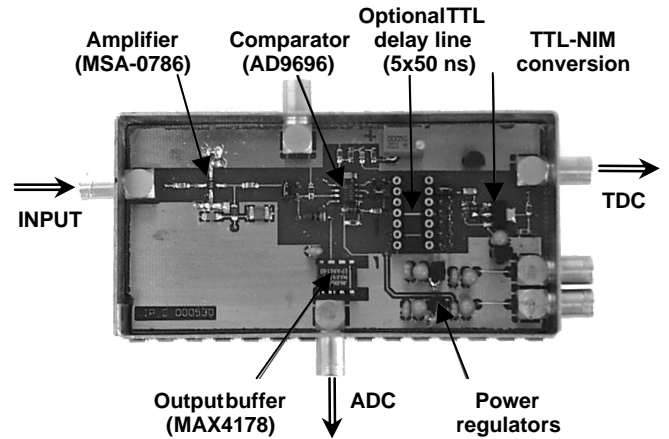

Figure 4: Layout of the amplifier-discriminator board.

A LeCroy 2249W charge-sensitive ADC sensed the analog outputs of both channels, the fast (electron) component of the signal being selected by a 40 ns gate width. The system was calibrated by injection of a set of known charge amounts using one of the preamplifier's test inputs, yielding an input-equivalent charge sensitivity of 2.1 fC per ADC bin, a charge range of 4.2 pC and a charge resolution of 3.2 fC ($1.5 \text{ bins } \sigma$).

V. RESULTS

A detail of the measured fast charge distribution is shown in Figure 7, for discriminator settings that correspond to input-equivalent charge cut-off values of 10, 25 and 50 fC. The sharp histogram edges (compatible with the measured 1.5 bin charge resolution) indicate a good correlation between the measured charge and the signal amplitude seen by the discriminator. This correlation is important because the measured time must be corrected using the charge information.

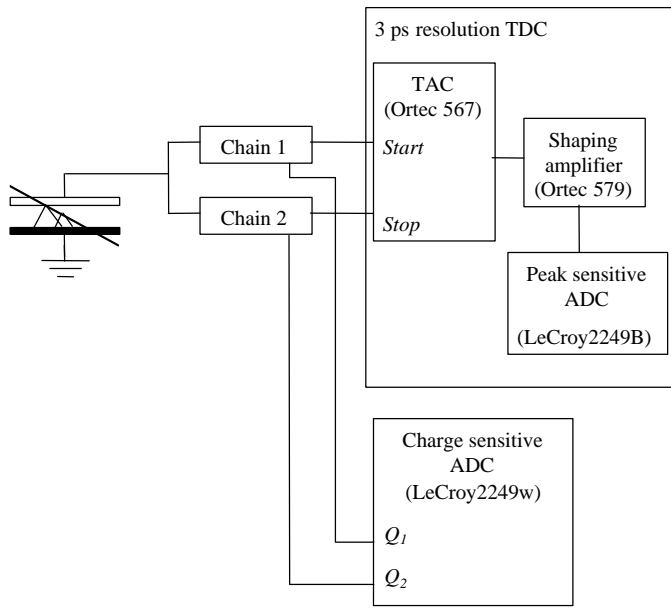

Figure 6: Simplified diagram of the timing resolution test circuit.

In order to measure the timing accuracy as a function of the signal charge, the charge spectrum was partitioned in conveniently sized regions and the timing accuracy calculated for each region. The charge dependence of the measured time was removed event-by-event via a linear correction:

$$t_{corr} = t_{meas} - (a + b Q)$$

where a and b were obtained by a linear least-squares fit to the data on each charge slice and Q is the measured signal charge.

The results are shown in Figure 8 for three different settings of the discriminating threshold, corresponding to the histograms shown in Figure 7. Additionally, in one of the curves the RPC was turned off, without disconnection, and a rectangular pulse with 1 ns rise time was applied to the test input of one of the preamplifiers.

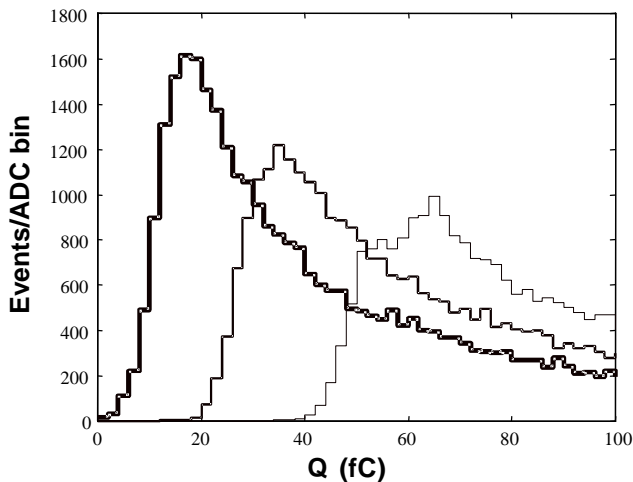

Figure 7: Details of the measured fast charge distribution for discriminator settings that correspond to an input-equivalent charge cut-off set at 10, 25 and 50 fC.

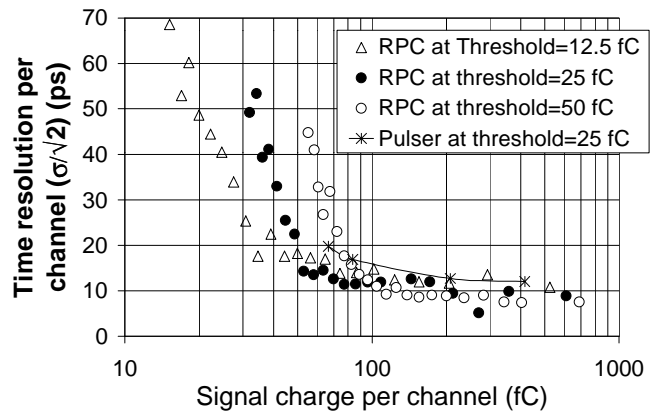

Figure 8: Measured time resolution as a function of signal charge for three different settings of the discriminating threshold.

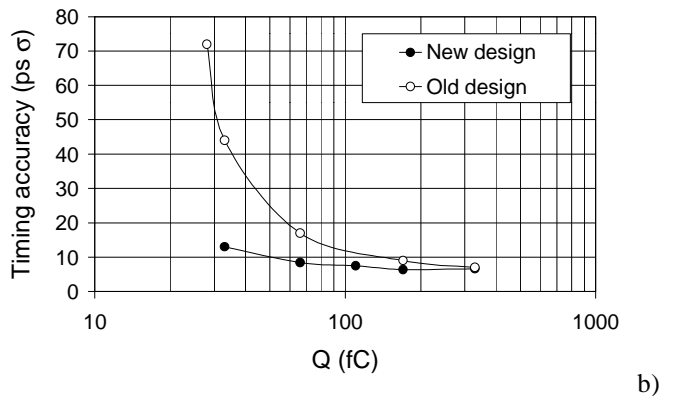
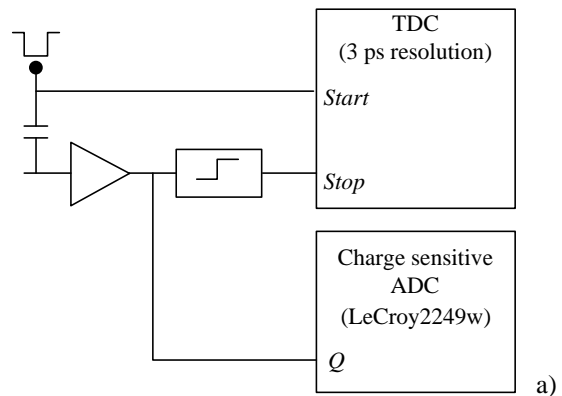

Figure 9: Comparative test between an older preamplifier version [1] and the present one. a) Simplified diagram of the test circuit. b) Test results. Clearly the new design shows a marked advantage for smaller pulses.

It can be seen that for signal charges larger than about 100 fC the timing accuracy is on the order of 10 ps. Curiously, the chamber-generated signals yield a better resolution than the pulser-generated ones, suggesting a steeper signal slope in the former case.

To determine whether the present preamplifier provided any improvement over older versions we tested it against a previous design [1] based on the BFG520 transistor in a common-emitter configuration. For this test (Figure 9a) an electronically generated voltage step with 1 ns risetime was

injected in the preamplifier input through a 1 pF capacitor and the time resolution, defined as the time jitter between the test signal edge and the discriminator signal was measured by the TDC described above. The results are shown in Figure 9b, being clear that the new design has a marked advantage for the smaller pulses.

It should be stressed that, for this type of purely electronic test, the timing resolution is clearly better than 10 ps.

As an example of application, a 0.16 m² chamber under beam test was readout with only four electronic channels, exhibiting a timing accuracy between 60 and 90 ps over 95% of its active area [8].

VI. CONCLUSIONS

In this paper we describe a new front-end electronics chain for accurate time and charge measurement in timing RPCs, in view of a possible application in the T₀ counter of the ALICE experiment [9].

Following the basic theory of gaseous detectors and of liner circuits it was hypothesised that the amplifier output signal (sensed by the discriminator) should be of the form $v(t) \approx i_0 Z(s) e^{st}$, being i_0 the initial current, $Z(s)$ the transimpedance of the circuit (chamber plus amplifier) and s a parameter related only to the gaseous amplification process in the detector. This hypothesis was experimentally proven and a value $s=8.9$ GHz was obtained.

The circuit was built solely from commercially available and inexpensive integrated circuits. The analog two-stage amplifier, based on MMICs, had a bandwidth of 2.5 GHz and a combined power gain of 32 dB. The amplified signal was sensed by a fast comparator chip followed by an optional TTL delay line and converted to the fast-NIM standard. The signal was also made externally available via an analog buffer, for monitoring and charge measurement purposes.

Tests with realistic signals from an RPC yielded a timing resolution around 10 ps σ for signal charges above 100 fC and a charge resolution of 3.2 fC. The new design shows a much improved resolution when compared with an older version, particularly for the smaller signals.

A 0.16 m² chamber readout with only 4 of the present front-end chains has reached a timing accuracy between 60 and 90 ps over 95% of its active area.

VII. ACKNOWLEDGEMENTS

We are grateful to Dr. P. Moritz of GSI, Darmstadt, Germany, for suggesting the use of MMICs for the analog part of the circuit and for providing chip and circuit samples.

Our colleagues, Armando Policarpo, Rui Marques, Francisco Fraga, Vitaly Chepel, Vladimir Solobov and Américo Pereira have also contributed variedly and valuably.

This work was supported by "Fundação para a Ciência e Tecnologia" under the contract CERN/P/FIS/15198/1999.

VIII. REFERENCES

- [1] P. Fonte, R. Ferreira Marques, J. Pinhão, N. Carolino and A. Policarpo "High-Resolution RPCs for Large TOF Systems" Nucl. Instr. and Meth. in Phys. Res. A, 449 (2000) 295.
- [2] A. Akindinov et al., "A Four-Gap Glass-RPC Time Of Flight Array with 90 Ps Time Resolution", ALICE note ALICE-PUB-99-34, preprint CERN-EP-99-166, submitted to IEEE Trans. Nucl. Sci.
- [3] P. Fonte and V. Peskov. "High-Resolution TOF with RPCs", oral communication presented in the "PSD99 - 5th International Conference on Position-Sensitive Detectors", 13 - 17th September 1999, University College, London, to be published in Nucl. Instr. and Meth. in Phys. Res. A
- [4] P. Fonte, "High-Resolution Timing of MIPs with RPCs", oral communication presented in the "RPC99 - 5th International Workshop on Resistive Plate Chambers", 28 - 29th October 1999, Bari, Italy, to be published in Nucl. Instr. and Meth. in Phys. Res. A
- [5] H. Raether, "Electron Avalanches and Breakdown in Gases", Butterworths, London, 1964.
- [6] R. Thomas and A. Rosa, "Analysis and Design of Linear Circuits", Prentice Hall, New Jersey, USA (1998), pp. 617.
- [7] P. Moritz et al., "Diamond Detectors for Beam Diagnostics in Heavy-Ion Accelerators", Proc. of the 3rd European Workshop on Beam Diagnostics and Instrumentation for Particle Accelerators', DIPAC III, October 1997, <http://www.gsi.de/accelerator/conf/Dipac97.pdf>
- P. Moritz, E. Berdermann, K. Blasche, H. Stelzer, B. Voss, "Broadband Electronics for CVD-Diamond Detectors" ICNDST-7, Hongkong 07/2000, (to be published)
- [8] A. Blanco, N. Carolino, C. Finck, P. Fonte, R. Ferreira-Marques, A. Gobbi, M. Rosas and A. Policarpo, "A Large Area Timing RPC", in preparation.
- [9] ALICE, Technical Proposal, CERN/LHCC 95-71, LHCC/P3, December 15, 1995.